

# CONVECTION-STEAM OVEN

CVPE  
CVPE-S  
CVPE-2  
CVPE-S2  
FCVE  
FCVE-S  
FCVE-2  
FCVE-2S

TYPE: 6, 10, 20

---

## Spare parts

---

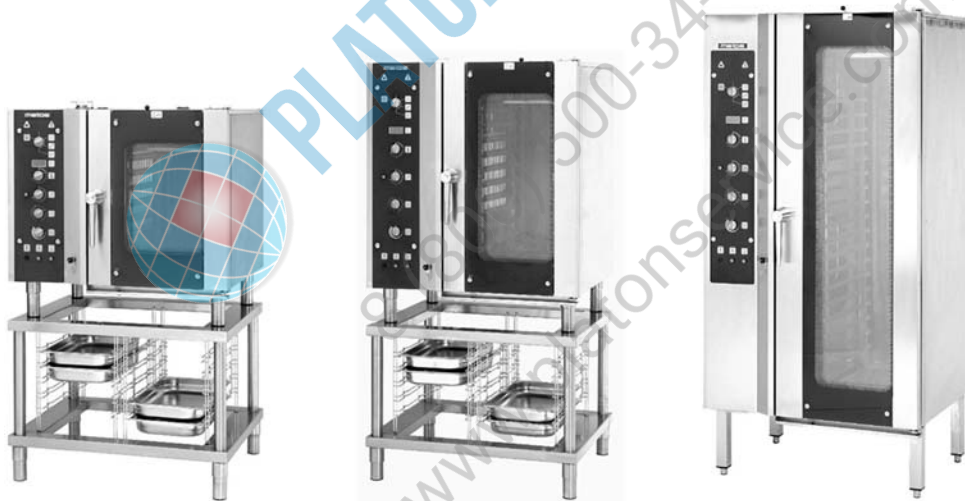

---

S/N:

Valid from: 28. 09. 2007

Rev.: 1.0



**PLATON**SERVICE

8 (800) 500-34-47

[www.platonservice.com](http://www.platonservice.com)

## 1. Spare parts

### Outer parts:

CVP10E,CVP10E-S,CVP10E-2,CVP10E-S2,CVP20E,CVP20E-S,CVP20E-2,CVP20E-S2,FCV10E,FCV10E-S,FCV10E-2,FCV10E-2S,FCV20E,FCV20E-S,FCV20E-2,FCV20E-2S 5

### Outer parts:

CVP6E,CVP6E-S,CVP6E-2,CVP6E-S2,FCV6E,FCV6E-S,FCV6E-2,FCV6E-2S 9

### Motor compartment components:

CVP6E,CVP6E-S,CVP6E-2,CVP6E-S2,CVP10E,CVP10E-S,CVP10E-2,CVP10E-S2,CVP20E,CVP20E-S,CVP20E-2,CVP20E-S2 11

### Control panel:

CVP6E,CVP6E-S,CVP6E-2,CVP6E-S2,CVP10E,CVP10E-S,CVP10E-2,CVP10E-S2,CVP20E,CVP20E-S,CVP20E-2,CVP20E-S2,FCV6E,FCV6E-S,FCV6E-2,FCV6E-2S,FCV10E,FCV10E-S,FCV10E-2,FCV10E-2S,FCV20E,FCV20E-S,FCV20E-2,FCV20E-2S 15

### Door :

CVP6E,CVP6E-S,CVP6E-2,CVP6E-S2,CVP10E,CVP10E-S,CVP10E-2,CVP10E-S2,CVP20E,CVP20E-S,CVP20E-2,CVP20E-S2,FCV6E,FCV6E-S,FCV6E-2,FCV6E-2S,FCV10E,FCV10E-S,FCV10E-2,FCV10E-2S,FCV20E,FCV20E-S,FCV20E-2,FCV20E-2S 17

**Steam generator:**

**CVP6E,CVP6E-S,CVP6E-2,CVP6E-S2,CVP10E,CVP10E-S,CVP10E-2,CVP10E-S2,CVP20E,CVP20E-S,CVP20E-2,CVP20E-S2,FCV6E,FCV6E-S,FCV6E-2,FCV6E-2S,FCV10E,FCV10E-S,FCV10E-2,FCV10E-2S,FCV20E,FCV20E-S,FCV20E-2,FCV20E-2S** 19

**Door handle:**

**CVP6E,CVP6E-S,CVP6E-2,CVP6E-S2,CVP10E,CVP10E-S,CVP10E-2,CVP10E-S2,CVP20E,CVP20E-S,CVP20E-2,CVP20E-S2,FCV6E,FCV6E-S,FCV6E-2,FCV6E-2S,FCV10E,FCV10E-S,FCV10E-2,FCV10E-2S,FCV20E,FCV20E-S,FCV20E-2,FCV20E-2S** 21



**PLATON SERVICE**  
8 (800) 500-34-41  
www.platonservice.com

## 1.1 Voltage codes

Voltage	Voltage code
A	3/N/PE~400/230V 50Hz
B	~250V 16A 50Hz
C	3/N/PE~380/220V 50Hz
D	3/PE~200V 50-60Hz
F	2/PE 220-240V 50Hz
G	3/N/PE~415/240V 50Hz
H	3/PE~230V 50Hz
I	3/PE~220V 60Hz
J	3/PE~380 50Hz
K	3/PE~400V 50Hz
L	3/PE~415V 50Hz
M	3/PE~440V 60Hz
N	3/PE~460V 60Hz
O	3/PE~480V 60Hz
P	1/N/PE~220-240V 50Hz
R	2/PE~220-230V 60Hz
S	3/N/PE~400/230V 50Hz
T	3/PE~230V 60Hz
U	1/N/PE~100V 50-60Hz

## 1.2 Product codes

Product code	Full name
Model codes	
CVPE	CVPE
CVPES	CVPE-S
CVPE2	CVPE-2
CVPES2	CVPE-S2
FCVE	FCVE
FCVES	FCVE-S
FCVE2	FCVE-2
FCVE2S	FCVE-2S
Type codes	
6	6
10	10
20	20
Accessory codes	

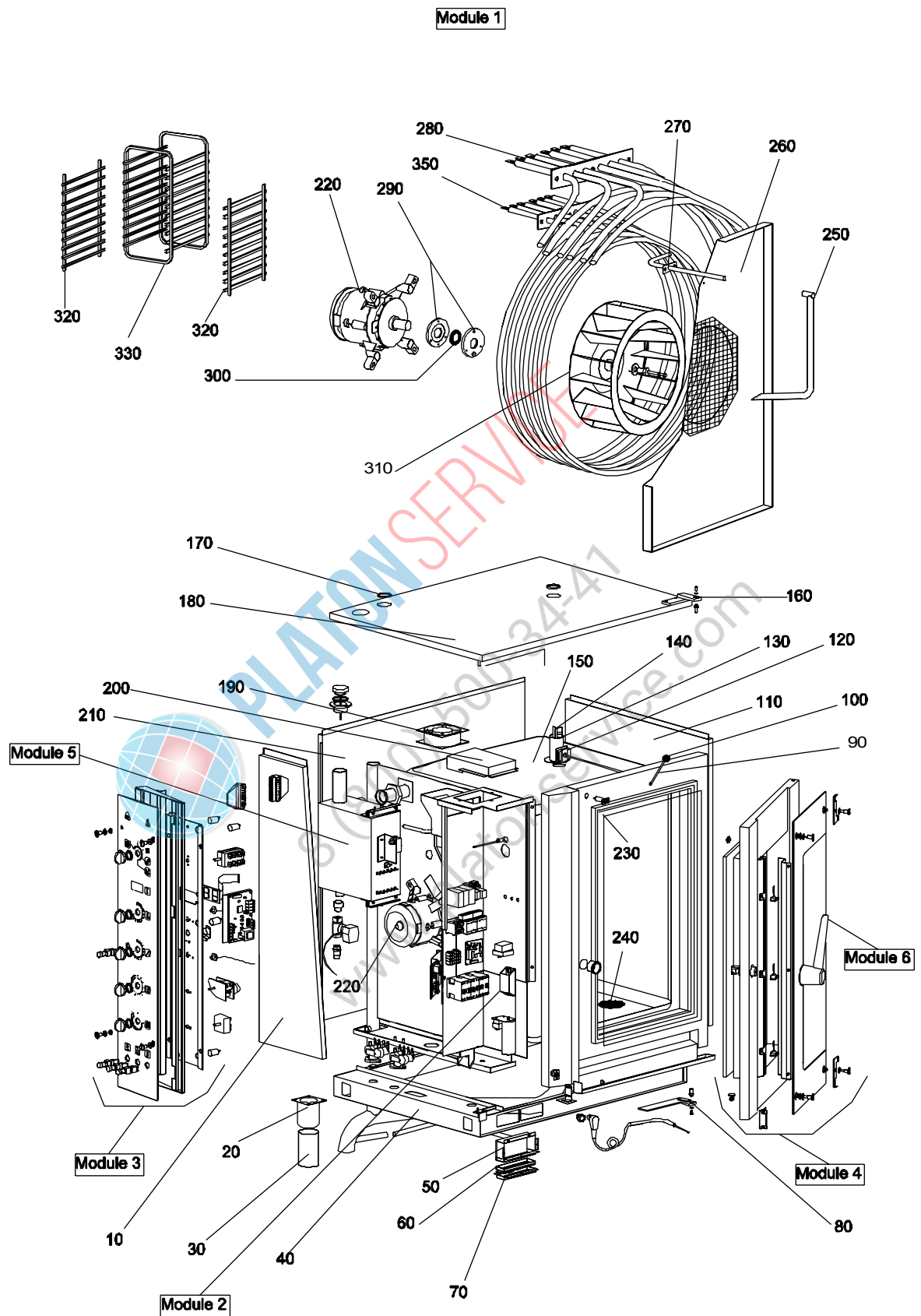

## Spare parts

ID	Model	Type	Description	P-code
<b>Module:Outer parts: CVP10E,CVP10E-S,CVP10E-2,CVP10E-S2,CVP20E,CVP20E-S,CVP20E-2,CVP20E-S2,FCV10E ,FCV10E-S,FCV10E-2,FCV10E-2S,FCV20E,FCV20E-S,FCV20E-2,FCV20E-2S</b>				
10		20	Left side	3111300
10		10	Left side	3111200
20		10,20	Foot-holder sleeve	6A028620
30		10,20	Leg	6A028610
40		20	Frame	3100100
40		10	Frame	3100000
50		10,20	Air filter support	3111800
60		10,20	Lower air filter support	3112000
70		10,20	Central air filter support	3111900
80		10,20	Lower door hinge	3106800
90		20	Chamber steam blowdown valve	3115250
90		10	Chamber steam blowdown valve	3115200
100		10,20	Shaft valve black knob	6A019350
110		20	Right side	3111000
110		10	Right side	3110900
120		10,20	Shaft rotation block	3115300
130		10,20	Steam exhaust valve pipe	3115000
140		10,20	Steam exhaust valve	3115100
150		20	Chamber	3100900
150		10	Chamber	3100800
160		10,20	Upper door hinge	3106700
170		10,20	Seal	2510675
180		20	Top	3111700
180		10	Top	3111600
190		10,20	Cooling fan	3102350
200		10,20	Electric components air conveyer	3113900
210		20	Back panel	3110700
210		10	Back panel	3110600

CVPE=CVPE,CVPES=CVPE-S,CVPE2=CVPE-2,CVPES2=CVPE-S2,FCVE=FCVE,FCVES=FCVE-S,FCVE2=FCVE-2,FCVE2S,FCVE-2S

6=6, 10=10, 20=20

A=3/N/PE~400/230V 50Hz

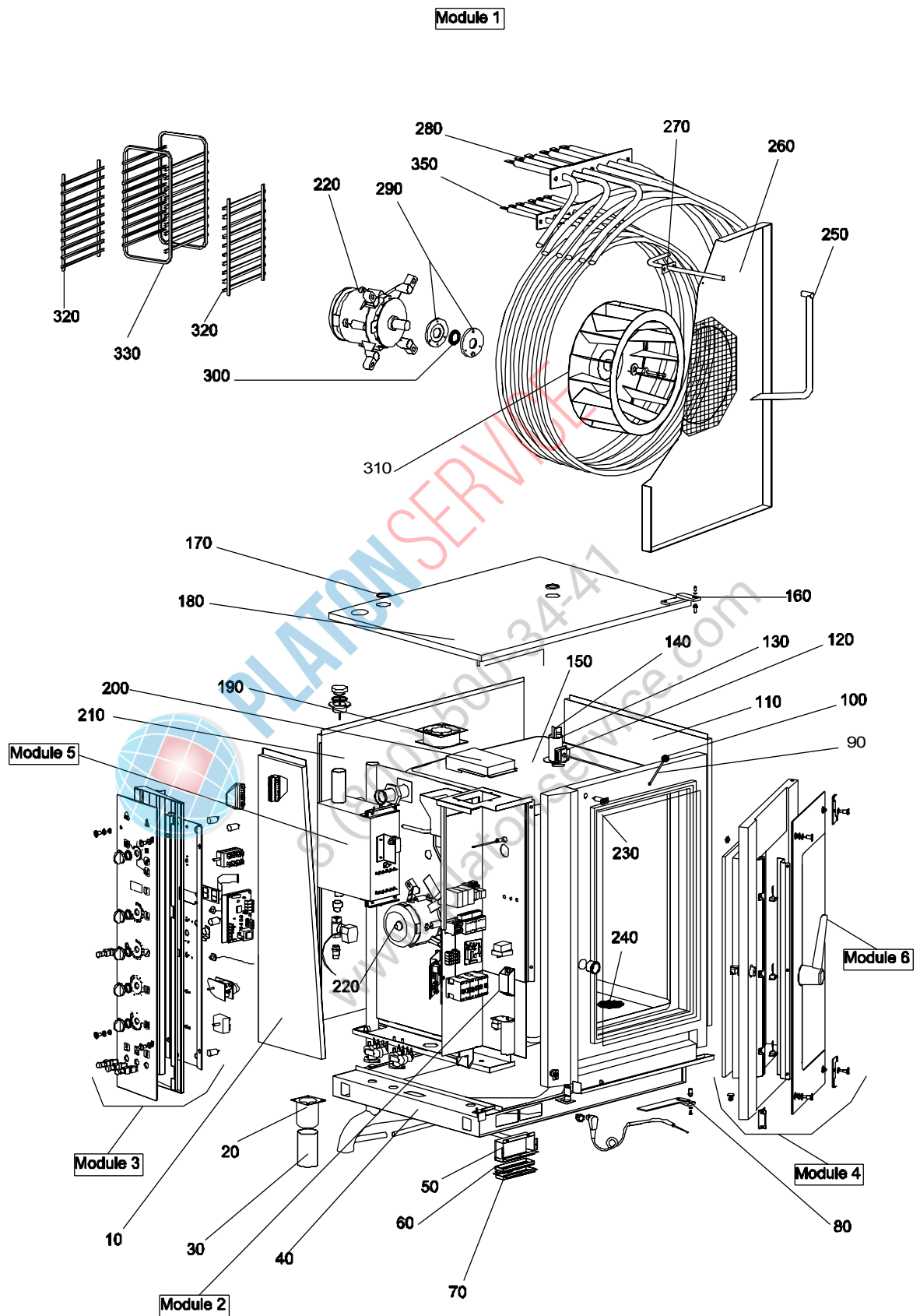



## Spare parts

ID	Model	Type	Description	P-code
<b>Module:Outer parts: CVP10E,CVP10E-S,CVP10E-2,CVP10E-S2,CVP20E,CVP20E-S,CVP20E-2,CVP20E-S2,FCV10E ,FCV10E-S,FCV10E-2,FCV10E-2S,FCV20E,FCV20E-S,FCV20E-2,FCV20E-2S</b>				
220	CVPE,CVPES,FCVE,FCVES	10,20	three-phase motor	3102300
220	CVPE2,CVPES2,FCVE2,FCVE2S	10,20	Fan motor, 2-speed	3102310
230		20	Door seal	3108800
230		10	Door seal	3108700
240		10,20	Exhaust grid	3114900
250		20	Chamber interior water pipe	3116250
250		10	Chamber interior water pipe	3116220
260		20	Fan-cover panel	3101200
260		10	Fan-cover panel	3101120
270		20	Chamber exterior water pipe	3116000
270		10	Chamber exterior water pipe	3116020
280		20	Heating element 10500 W	6A037470
280		10	Heating element 10500 W	6A037480
290		10,20	Motor oil seal holder	3102500
300		10,20	Motor oil seal	3102400
310		20	12-blade fan 50Hz	3101630
310		10	16-blade fan 50Hz	3101600
320		20	Grids holder	3122700
320		10	Grids holder	3122600
330		20	Tray-holder trolley	3120200
330		10	Tray-holder trolley	3120100
350		20	Heating element 9000 W	6A037475
350		10	Heating element 7500 W	6A037460

CVPE=CVPE,CVPES=CVPE-S,CVPE2=CVPE-2,CVPES2=CVPE-S2,FCVE=FCVE,FCVES=FCVE-S,FCVE2=FCVE-2,FCVE2S,FCVE-2S

6=6, 10=10, 20=20

A=3/N/PE~400/230V 50Hz

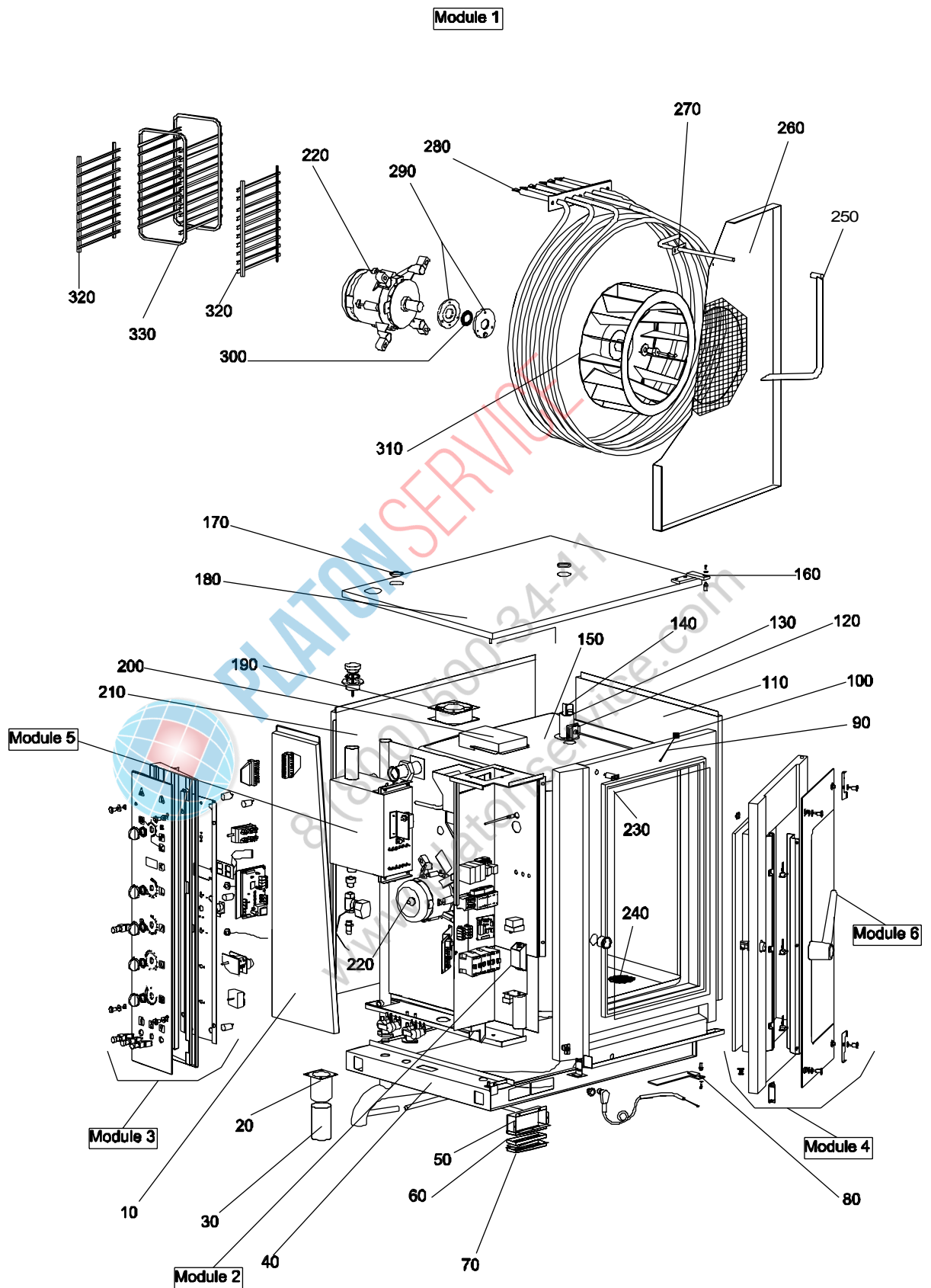

## Spare parts

ID	Model	Type	Description	P-code
<b>Module:Outer parts: CVP6E,CVP6E-S,CVP6E-2,CVP6E-S2,FCV6E,FCV6E-S,FCV6E-2,FCV6E-2S</b>				
10		6	Left side	3111100
20		6	Foot-holder sleeve	6A028620
30		6	Leg	6A028610
40		6	Frame	3100000
50		6	Air filter support	3111800
60		6	Lower air filter support	3112000
70		6	Central air filter support	3111900
80		6	Lower door hinge	3106800
90		6	Chamber steam blowdown valve	3115200
100		6	Shaft valve black knob	6A019350
110		6	Right side	3110800
120		6	Shaft rotation block	3115300
130		6	Steam exhaust valve pipe	3115000
140		6	Steam exhaust valve	3115100
150		6	Chamber	3100700
160		6	Upper door hinge	3106700
170		6	Seal	2510675
180		6	Top	3111600
190		6	Cooling fan	3102350
200		6	Electric components air conveyer	3113900
210		6	Back panel	3110500
220	CVPE,CVPES,FCVE,FCVES	6	three-phase motor	3102300
220	CVPE2,CVPES2,FCVE2,FCVE2S	6	Fan motor, 2-speed	3102310
230		6	Door seal	3108600
240		6	Exhaust grid	3114900
250		6	Chamber interior water pipe	3116120
260		6	Fan-cover panel	3101020
270		6	Chamber exterior water pipe	3116020
280		6	Heating element 7500 W	6A037460
290		6	Motor oil seal holder	3102500
300		6	Motor oil seal	3102400
310		6	16-blade fan 50Hz	3101600
320		6	Grids holder	3122500
330		6	Tray-holder trolley	3120000

CVPE=CVPE,CVPES=CVPE-S,CVPE2=CVPE-2,CVPES2=CVPE-S2,FCVE=FCVE,FCVES=FCVE-S,FCVE2=FCVE-2,FCVE2S,FCVE-2S

6=6, 10=10, 20=20

A=3/N/PE~400/230V 50Hz

Module 2

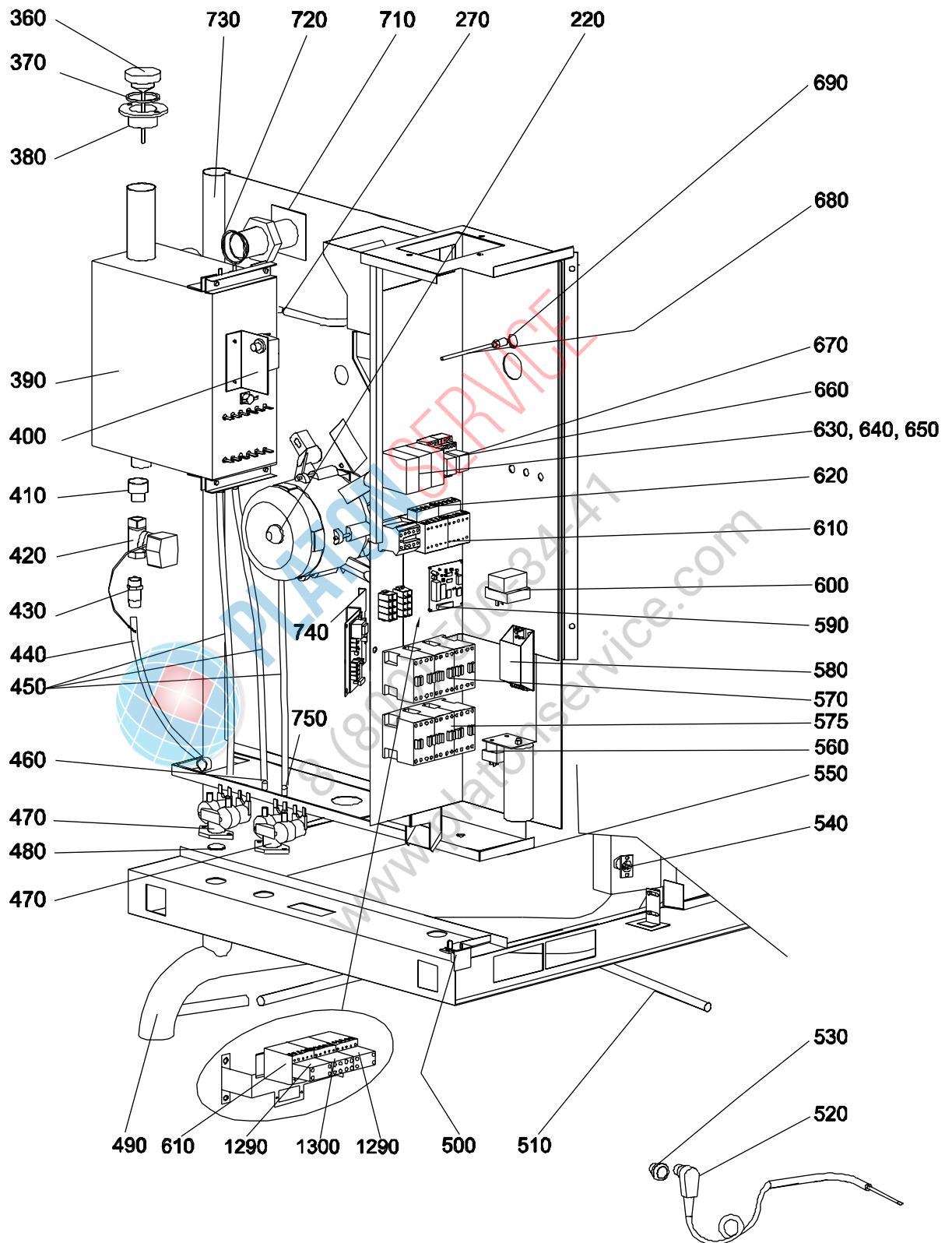

## Spare parts

ID	Model	Type	Description	P-code
<b>Module: Motor compartment components: CVP6E,CVP6E-S,CVP6E-2,CVP6E-S2,CVP10E,CVP10E-S,CVP10E-2,CVP10E-S2,CVP20E,CVP20E-S,CVP20E-2,CVP20E-S2,FCV6E,FCV6E-S,FCV6E-2,FCV6E-2S,FCV10E,FCV10E-S,FCV10E-2,FCV10E-2S,FCV20E,FCV20E-S,FCV20E-2,FCV20E-2S</b>				
220	CVPE,CVPES,FCVE,FCVES	6,10,20	three-phase motor	3102300
220	CVPE2,CVPES2,FCVE2,FCVE2S	6,10,20	Fan motor, 2-speed	3102310
270		6,10,20	Chamber exterior water pipe	3116000
360		6,10,20	Safety valve	3116300
370		6,10,20	Safety valve seal	3116330
380		6,10,20	Steam safety valve holder	3116350
390		10,20	Steam generator 15 kW	3103400
390		6	Steam generator 7.5 kW	3103300
400		6,10,20	Safety thermostat boiler	6A046185
410		6,10,20	Reduction	6A020220
420		6,10,20	Motor valve	3198150
430		6,10,20	Pipe holder	6A020225
440		6,10,20	Rubber pipe	3103632
450		6,10,20	Rubber pipe for water connection	3103635
460		6,10,20	Capacity reducer (black)	3103642
470		6,10,20	Electromagnetic valve, 2-way	3103610
480		6,10,20	Flow regulator (red)	3103643
490		20	Drain pipe	3105230
490		6,10	Drain pipe	3105130
500		6,10,20	Swivel panel holders	3109900
510		20	Tray drainage connecting hose	3100650
510		6,10	Tray drainage connecting hose	3100450
520	CVPE,CVPES,FCVE,FCVES	6,10,20	Core temperature probe	3103280
530	CVPE,CVPES,FCVE,FCVE2S	6,10,20	Panel connector cap	3103290
540	CVPE,CVPES,FCVE,FCVE2S	6,10,20	Three-pole panel connector	3103285
550		20	Bottom panel	3113300
550		6,10	Bottom panel	3113200
560		6,10,20	Thermostat	6A046195

CVPE=CVPE,CVPES=CVPE-S,CVPE2=CVPE-2,CVPES2=CVPE-S2,FCVE=FCVE,FCVES=FCVE-S,FCVE2=FCVE-2,FCVE2S,FCVE-2S

6=6, 10=10, 20=20

A=3/N/PE~400/230V 50Hz

Module 2

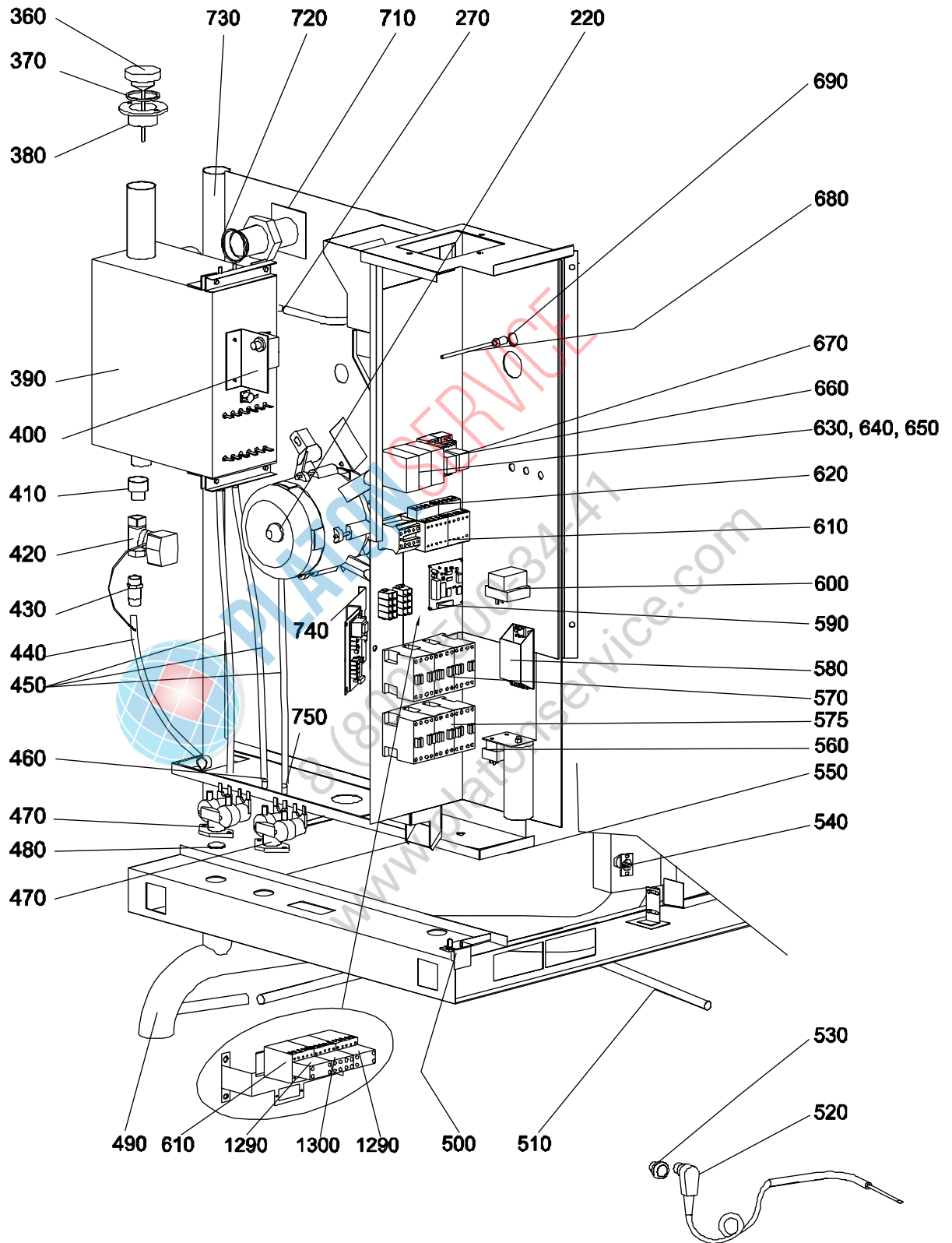

## Spare parts

ID	Model	Type	Description	P-code
<b>Module: Motor compartment components: CVP6E,CVP6E-S,CVP6E-2,CVP6E-S2,CVP10E,CVP10E-S,CVP10E-2,CVP10E-S2,CVP20E,CVP20E-S,CVP20E-2,CVP20E-S2,FCV6E,FCV6E-S,FCV6E-2,FCV6E-2S,FCV10E,FCV10E-S,FCV10E-2,FCV10E-2S,FCV20E,FCV20E-S,FCV20E-2,FCV20E-2S</b>				
570		20	Contactora	6A047036
570		10	Contactora	6A047034
570		6	Contactora	6A047037
575		6	Steam generator contactora	6A047031
575		10,20	Steam generator contactora	6A047034
580		6,10,20	Chamber light transformer	6A047060
590		6,10,20	Chamber lights time relay + Reverser 50 Hz	3103241
600		6,10,20	Safety thermostat	6A046190
610		6,10,20	Minicontactor	6A047037
620		6,10,20	Auxiliary contact	6A047038
630		6,10,20	Fuse-holder terminal	6A034500
640		6,10,20	Fuse 1A	6A034510
650		6,10,20	Fuse 2A	6A034520
660		6,10,20	Relay	6A047071
670		6,10,20	Boiler control relay	6A047070
680		6,10,20	Chamber probe with wire L=800 mm	3103275
690		6,10,20	Nut	6A011607
710		6,10,20	Connection pipe	3116400
720		6,10,20	O-ring	3116430
730		10,20	Drain vent pipe	3105280
730		6	Drain vent pipe	3105180
740		6,10,20	Boiler control card	3103255
750		6,10,20	Capacity reducer (green)	3103637
1290	CVPE2,CVPES2,FCVE2,FCVE2S	6,10,20	Auxiliary contact	6A047038
1300	CVPE2,CVPES2,FCVE2,FCVE2S	6,10,20	Auxiliary contact	6A047039

CVPE=CVPE,CVPES=CVPE-S,CVPE2=CVPE-2,CVPES2=CVPE-S2,FCVE=FCVE,FCVES=FCVE-S,FCVE2=FCVE-2,FCVE2S,FCVE-2S

6=6, 10=10, 20=20

A=3/N/PE~400/230V 50Hz

**Module 3**

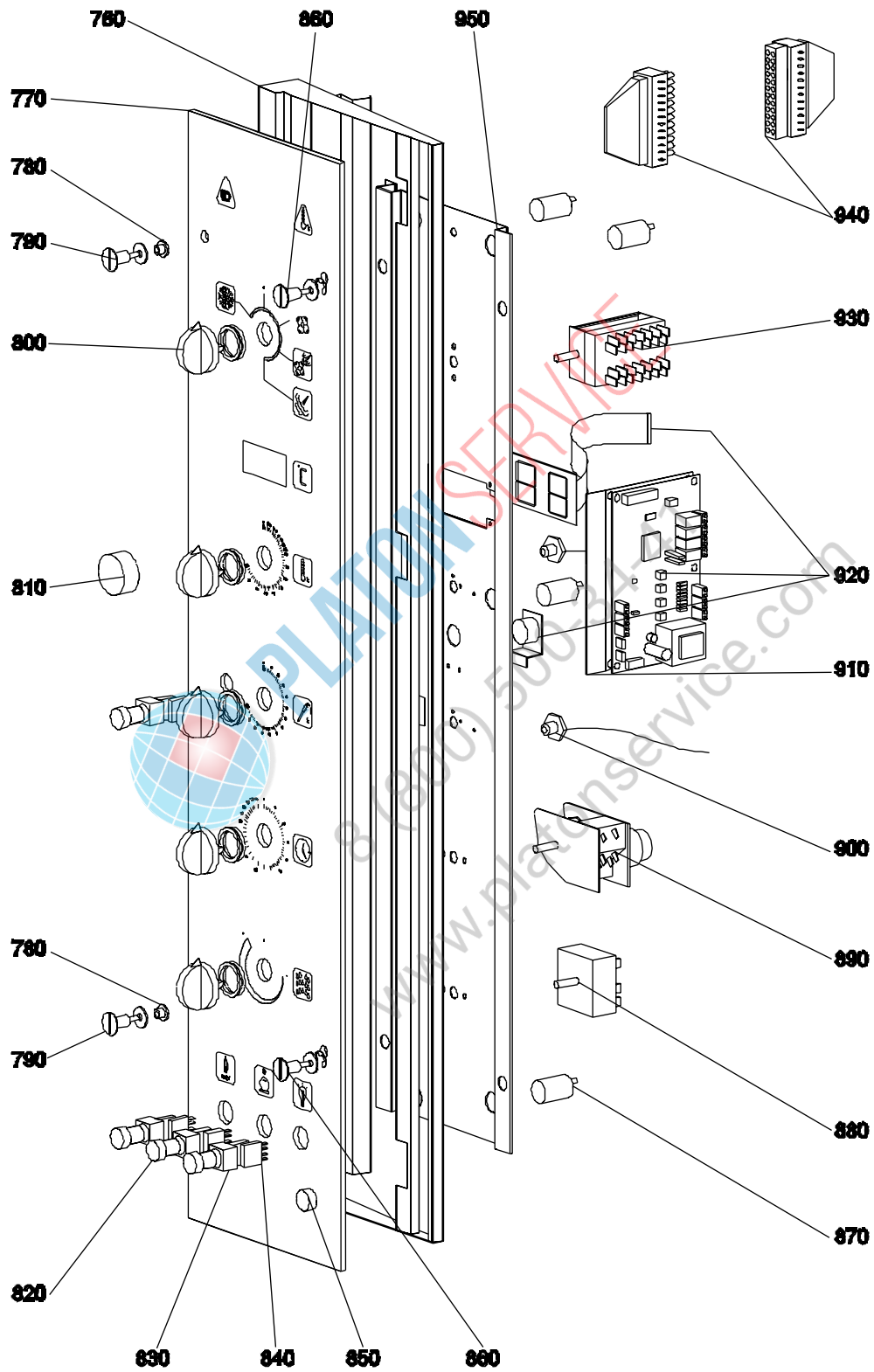



## Spare parts

ID	Model	Type	Description	P-code
<b>Module: Control panel: CVP6E,CVP6E-S,CVP6E-2,CVP6E-S2,CVP10E,CVP10E-S,CVP10E-2,CVP10E-S2,CVP20E,CVP20E-S,CVP20E-2,CVP20E-S2,FCV6E,FCV6E-S,FCV6E-2,FCV6E-2S,FCV10E,FCV10E-S,FCV10E-2,FCV10E-2S,FCV20E,FCV20E-S,FCV20E-2,FCV20E-2S</b>				
760		10,20	Glass control panel swivel support	3109800
760		6	Glass control panel swivel support	3109700
770	FCVE,FCVES,FCVE2,FCVE2S	10,20	Control panel glass	3108565
770	CVPE,CVPES,CVPE2,CVPES2	10,20	Control panel glass	3108560
770	FCVE,FCVES,FCVE2,FCVE2S	6	Control panel glass	3108555
770	CVPE,CVPES,CVPE2,CVPES2	6	Control panel glass	3108550
780		6,10,20	Glassdoor back right screw	3106060
790		6,10,20	Glassdoor front right screw	3106061
800	FCVE,FCVES,FCVE2,FCVE2S	6,10,20	Black oven knob kit	3199025
800	CVPE,CVPES,CVPE2,CVPES2	6,10,20	Grey oven knob kit	3199020
810		6,10,20	22-mm hole cap	3102870
820		6,10,20	Push-button body	3102801
830		6,10,20	Contact holder	3102802
840		6,10,20	Contact	3102803
850		6,10,20	16-mm hole cap	3102860
860		6,10,20	Glass door left hand screw	3106050
870		6,10,20	Pilot lamp	3102850
880		6,10,20	Energy regulator	6A049320
890		6,10,20	Timer 120min. 60 Hz	6A047080
900		6,10,20	Card potentiometer	3103260
910		6,10,20	Board support	3113150
920		6,10,20	(KIT) Temperature control card	3198400
930		6,10,20	Switch	6A046015
940		6,10,20	24 Poles Connectors	3102840
950		10,20	Back panel	3110100
950		6	Back panel	3110000

CVPE=CVPE,CVPES=CVPE-S,CVPE2=CVPE-2,CVPES2=CVPE-S2,FCVE=FCVE,FCVES=FCVE-S,FCVE2=FCVE-2,FCVE2S,FCVE-2S

6=6, 10=10, 20=20

A=3/N/PE~400/230V 50Hz

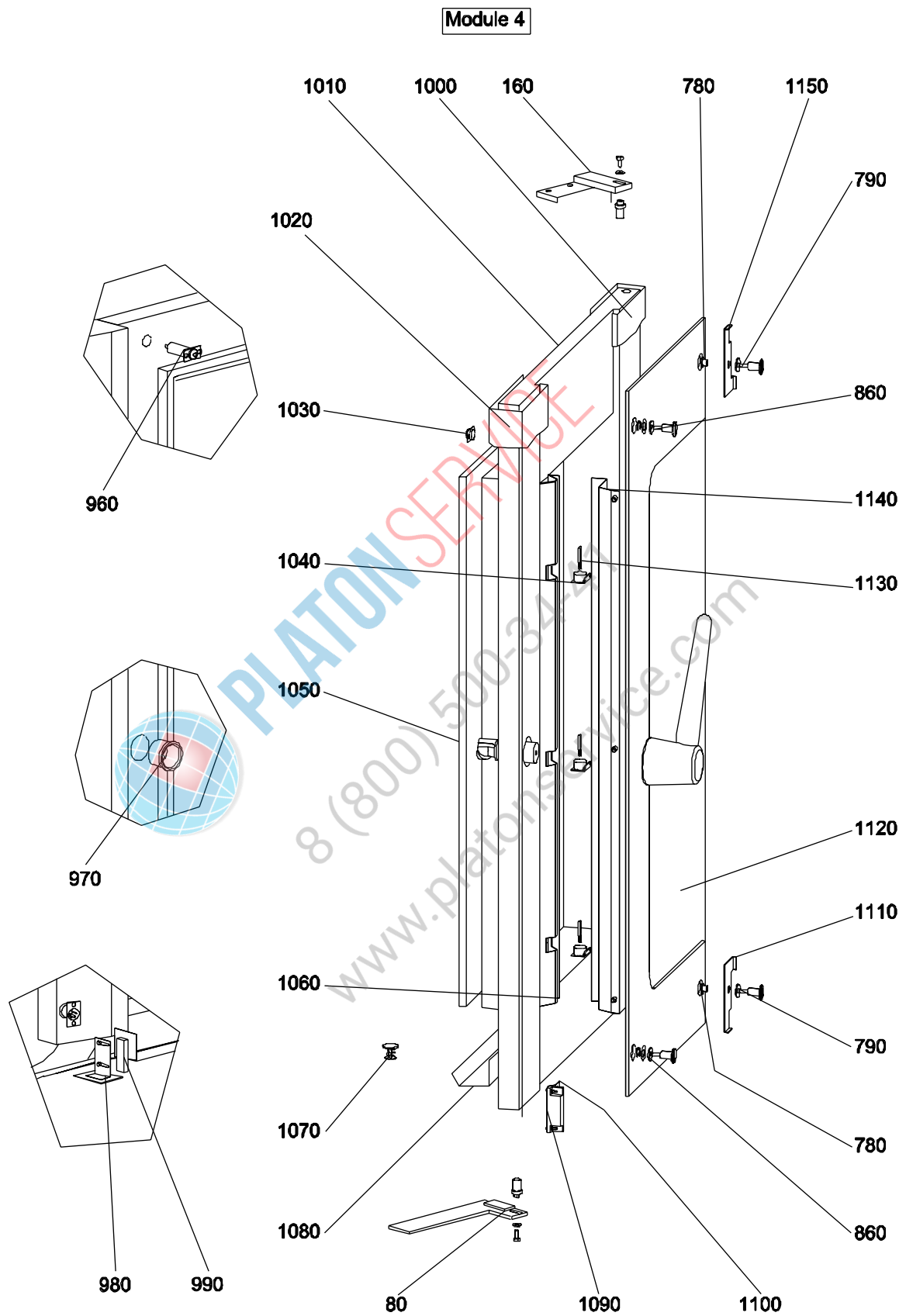

## Spare parts

ID	Model	Type	Description	P-code
<b>Module: Door : CVP6E,CVP6E-S,CVP6E-2,CVP6E-S2,CVP10E,CVP10E-S,CVP10E-2,CVP10E-S2,CVP20E,CVP20E-S,CVP20E-2,CVP20E-S2,FCV6E,FCV6E-S,FCV6E-2,FCV6E-2S,FCV10E,FCV10E-S,FCV10E-2,FCV10E-2S,FCV20E,FCV20E-S,FCV20E-2,FCV20E-2S</b>				
80		6,10,20	Lower door hinge	3106800
160		6,10,20	Upper door hinge	3106700
780		6,10,20	Glassdoor back right screw	3106060
790		6,10,20	Glassdoor front right screw	3106061
860		6,10,20	Glass door left hand screw	3106050
960		6,10,20	Front-panel contact	3108870
970		6,10,20	Door closing striking plate	3107910
980		6,10,20	Door switch holder	3106660
990		6,10,20	Door switch with wire L=2000 mm	6A047085
1000		10,20	Right hand door guard skirt	3107100
1000		6	Right hand door guard skirt	3107000
1010		20	Door frame	3106200
1010		10	Door frame	3106100
1010		6	Door frame	3106000
1020		10,20	Left hand door guard skirt	3107300
1020		6	Left hand door guard skirt	3107200
1030		6,10,20	Door switch	3108879
1040		6,10,20	Lamp holder	3108860
1050		20	Interior glass door	3108500
1050		10	Interior glass door	3108400
1050		6	Interior glass door	3108300
1060		10,20	Door lights parabola	3107500
1060		6	Door lights parabola	3107400
1070		6,10,20	Door tray cap	3106355
1080		20	Door tray	3106400
1080		6,10	Door tray	3106300
1090		6,10,20	Limit switch magnet	3108890
1100		6,10,20	Door magnet holding holders	3106670
1110		6,10,20	Glass door lower hinge	3106600
1120	FCVE,FCVES,FCVE2,FCVE2S	20	Door external glass	3108250
1120	CVPE,CVPES,CVPE2,CVPES2	20	Door external glass	3108200
1120	FCVE,FCVES,FCVE2,FCVE2S	10	Door external glass	3108150
1120	CVPE,CVPES,CVPE2,CVPES2	10	Door external glass	3108100
1120	FCVE,FCVES,FCVE2,FCVE2S	6	Door external glass	3108050
1120	CVPE,CVPES,CVPE2,CVPES2	6	Door external glass	3108000
1130		6,10,20	Halogen lamp	3108850
1140		10,20	Door light parabola guard	3107700
1140		6	Door light parabola guard	3107600
1150		6,10,20	Glass door upper hinge	3106500

CVPE=CVPE,CVPES=CVPE-S,CVPE2=CVPE-2,CVPES2=CVPE-S2,FCVE=FCVE,FCVES=FCVE-S,FCVE2=FCVE-2,FCVE2S,FCVE-2S

6=6, 10=10, 20=20

A=3/N/PE~400/230V 50Hz

**Module 5**

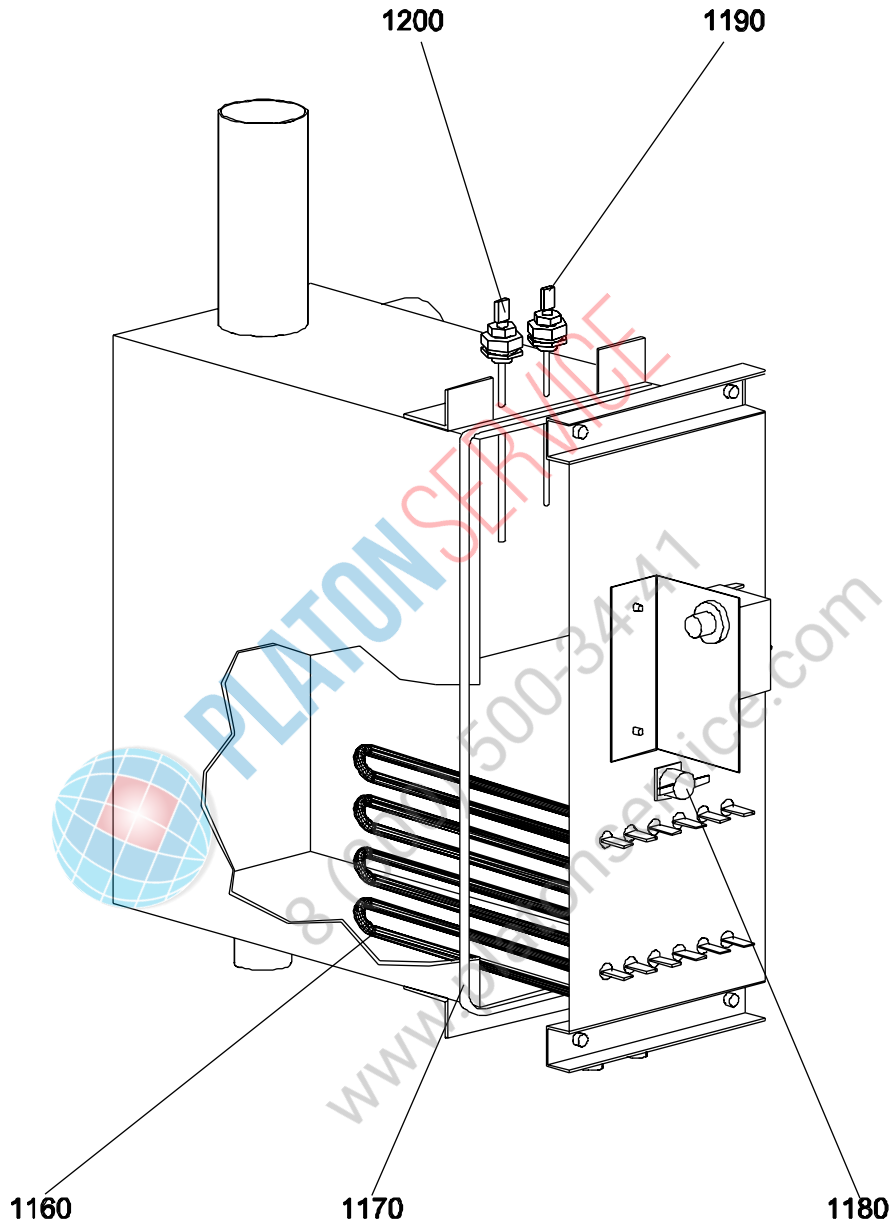

## Spare parts

ID	Model	Type	Description	P-code
<b>Module: Steam generator: CVP6E,CVP6E-S,CVP6E-2,CVP6E-S2,CVP10E,CVP10E-S,CVP10E-2,CVP10E-S2,CVP20E,CVP20E-S,CVP20E-2,CVP20E-S2,FCV6E,FCV6E-S,FCV6E-2,FCV6E-2S,FCV10E,FCV10E-S,FCV10E-2,FCV10E-2S,FCV20E,FCV20E-S,FCV20E-2,FCV20E-2S</b>				
1160		10,20	Heating element 15000 W	6A037484
1160		6	Heating element 7500 W	6A037483
1170		6,10,20	Gasket	6A037485
1180		6,10,20	Pre-heating boiler thermostat	6A046186
1190		6,10,20	Max. level sensor	6A037482
1200		6,10,20	Min. level sensor	6A037481

CVPE=CVPE,CVPES=CVPE-S,CVPE2=CVPE-2,CVPE2S=CVPE-S2,FCVE=FCVE,FCVES=FCVE-S,FCVE2=FCVE-2,FCVE2S,FCVE-2S

6=6, 10=10, 20=20

A=3/N/PE~400/230V 50Hz



PLATON SERVICE

8 (800) 500-34-41

www.platonservice.com

Module 6

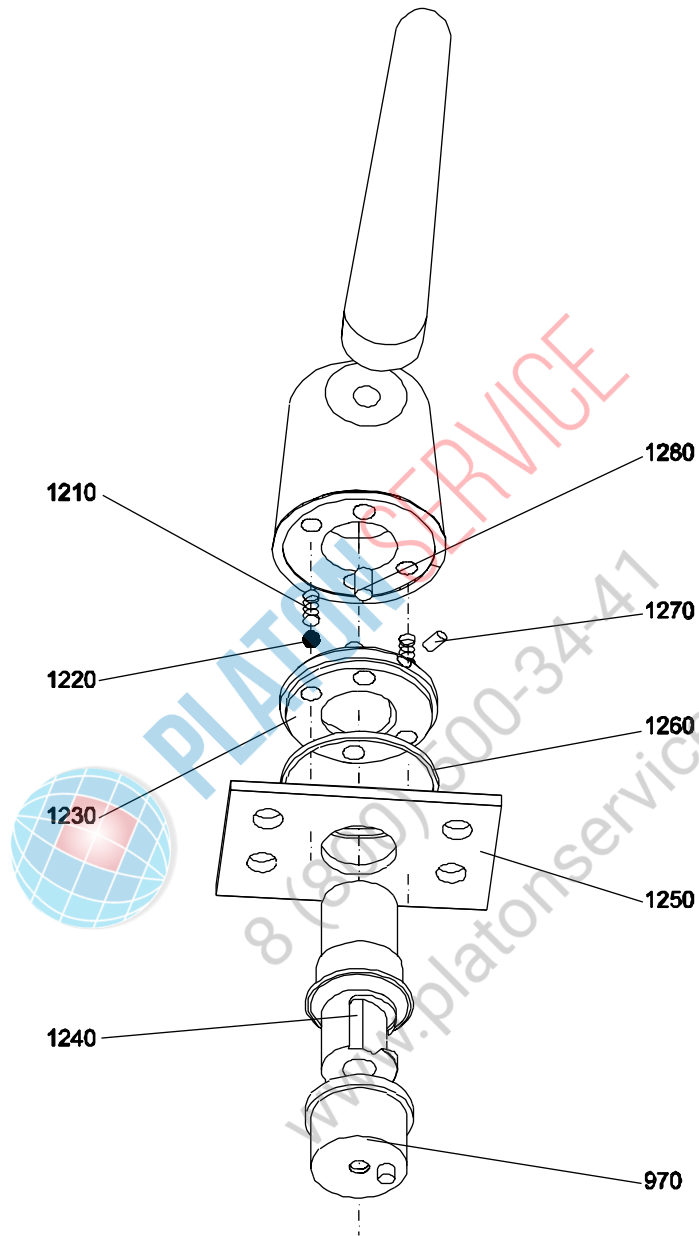

## Spare parts

ID	Model	Type	Description	P-code
<b>Module: Door handle: CVP6E,CVP6E-S,CVP6E-2,CVP6E-S2,CVP10E,CVP10E-S,CVP10E-2,CVP10E-S2,CVP20E,CVP20E-S,CVP20E-2,CVP20E-S2,FCV6E,FCV6E-S,FCV6E-2,FCV6E-2S,FCV10E,FCV10E-S,FCV10E-2,FCV10E-2S,FCV20E,FCV20E-S,FCV20E-2,FCV20E-2S</b>				
970		6,10,20	Door closing striking plate	3107910
1210		6,10,20	Spring	3107955
1220		6,10,20	Spheres	6A011409
1230		6,10,20	Block	3107935
1240		6,10,20	Door handle stop	3107991
1250		6,10,20	Bracket	3107945
1260		6,10,20	Ring	3107941
1270		6,10,20	Screw	3107950
1280		6,10,20	Pin	3107930

CVPE=CVPE,CVPES=CVPE-S,CVPE2=CVPE-2,CVPES2=CVPE-S2,FCVE=FCVE,FCVES=FCVE-S,FCVE2=FCVE-2,FCVE2S,FCVE-2S

6=6, 10=10, 20=20

A=3/N/PE~400/230V 50Hz



PLATON SERVICE  
8 (800) 500-34-41  
www.platonservice.com